

AIR DRUM SEPARATOR

COST-EFFICIENT SEPARATION OF 2-D FROM 3-D MATERIALS

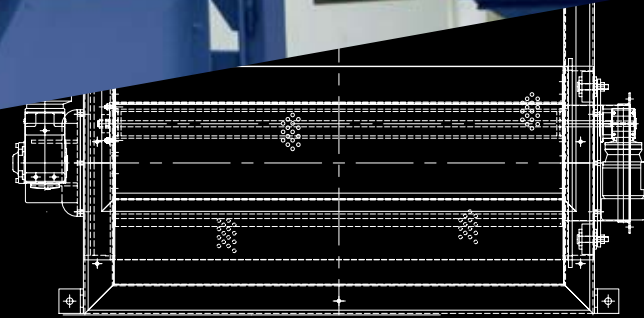
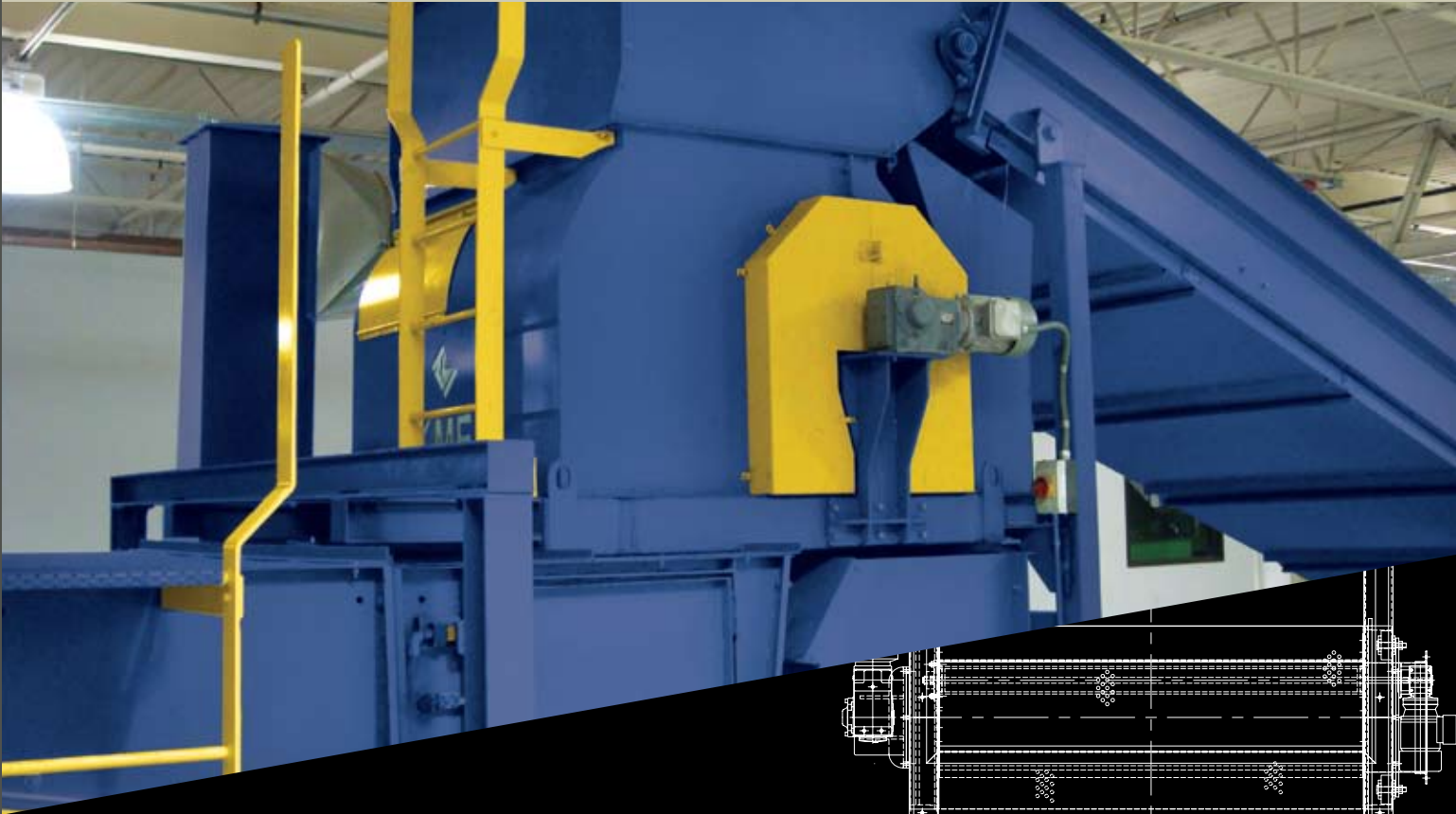

EASILY REMOVE FIBER FROM YOUR CONTAINER STREAM. DECREASE MANUAL SORTING AND LABOR. INCREASE END-PRODUCT QUALITY.

Now there is a simple, low-cost separator that decreases container stream contamination automatically. The Air Drum Separator easily removes 2-dimensional waste such as paper, shredded paper and film from 3-dimensional material streams in any MRF.

This simple, patented technology will make an immediate impact on throughput, labor hours, marketability of end-products—and your bottom-line.

SMALL FOOTPRINT. BIG SAVINGS.

The Air Drum Separator's compact size makes it an easy, low-cost retrofit for existing facilities. Its simple technology makes it quick

to install and keeps maintenance so low it's almost nonexistent. Add it to your existing facilities and be sure of seamless integration, prompt delivery, fast installation and rapid response to any questions or concerns.

CP MANUFACTURING: THE GLOBAL LEADER IN SEPARATION TECHNOLOGY.

All CP equipment is designed, built and field-proven 100% in our own recycling facility. From start to finish, from conception to completion, no company does more to provide cutting-edge solutions for MRFs around the world. Whether you process 100 tons a day or 1,000, you can profit from the innovation, experience and dependability of CP Manufacturing.



MATERIAL RECOVERY FACILITIES

AIR DRUM SEPARATOR

DESIGNED FOR EASY, LOW-COST RETROFIT AND MAXIMUM SEPARATION EFFICIENCY.

The Air Drum Separator applies vacuum technology through a rotating, perforated drum to draw flexible, two-dimensional material against the drum, separating it from rigid, three-dimensional material which bounces off. These two streams—2-D and 3-D—are then split for further processing. Drum speed and vacuum strength can be adjusted based on material stream content to provide maximum separation efficiency.

FEATURES AND BENEFITS

- :: Eliminates 2-D contaminants from 3-D material
- :: Low cost
- :: Low maintenance with minimal lubrication or cleaning required
- :: Long parts life
- :: Designed and engineered for easy retrofit
- :: Compact design for fast, simple installation
- :: Increases marketability of end-products
- :: Patented technology
- :: Adjustable drum speed and suction strength optimize separation efficiency depending on content of material stream
- :: Increases throughput
- :: Heavy-duty construction
- :: Two multiple model sizes available depending on MRF requirements

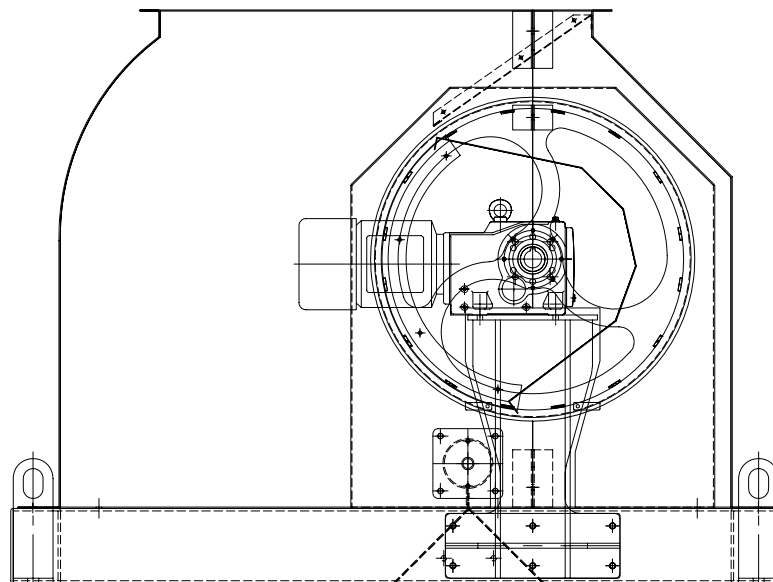

CP Manufacturing, Inc. ■ A Division of the CP Group of Companies ■ 1300 Wilson Avenue, National City, CA 91950, USA
(t) +1.619.477.3175 ■ (f) +1.619.477.2215 ■ (e) sales@cpmfg.com ■ (w) www.cpmfg.com

